



# NM200UW

## Nuclear Underwater Laser Scanner



*The NM200UW delivers precise dimensional measurements in the underwater radiation environments found in BWR and PWR vessels*



## Developed Specifically for the Nuclear Power Industry

The NM200UW nuclear underwater laser scanner is a landmark technology developed by Newton Labs in partnership with a major U.S. nuclear utility.

The NM200UW system combines rugged, industrial-grade hardware and electronics with sophisticated, Newton-developed software that compensates for the disruption of turbulence, heat and radioactivity characteristic of the in-vessel environment.

The scanner output is a point cloud so detailed, that when utilized with industry standard, three-dimensional software, a fully measurable CAD model can be generated.

The capability of the NM200UW to provide precise, reliable and efficient dimensioning of as-built features, as well as to track cycle-to-cycle degradation, is important to nuclear utility operators, who until now have relied heavily on indirect, inexact measurement techniques.

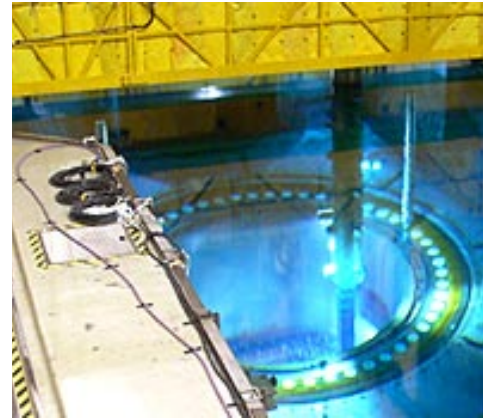

**NM200UW Nuclear Underwater Laser Scanner System**

### Construction and Materials:

- The 8 lb. (3.6 kg) scanner head is 6061T6 aluminum-hard anodized
- All fasteners and connectors are 316 Stainless Steel.
- Windows are high-strength fused silica
- O-rings and gaskets are Buna-N rubber and the cable jacket is LLDPE polyurethane.
- The scanner head is designed and built to tolerate radiation and has performed well in the presence of Gamma radiation levels of 5kR.
- The head is configured with alternate mounting points on most faces and is waterproof to a depth of 150 ft. (45.72 m).

### Components:

- The NM200UW scanner head encloses a laser, a high-resolution video camera and a high-intensity LED ring array
- The console unit contains scanner controls, processors and flat panel screen for viewing both the operating dashboard, as well as real-time video for positioning the scanner head
- The communications cable is a standard length of 150 ft. (45.72 m); lengths up to 300 ft. (91.44 m) may be special ordered
- Newton Labs Scanning Software
- Components are housed in two airline-transportable luggage cases

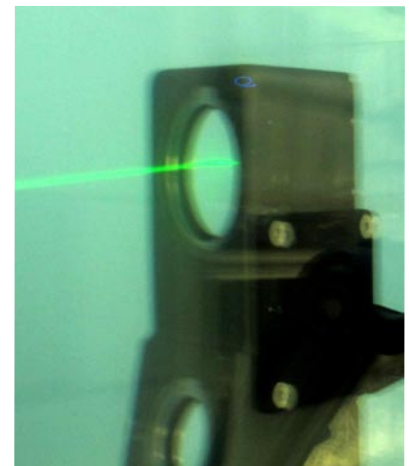

**NEWTON**

## Precise, Reliable and Efficient In-Vessel Dimensioning



Beam Bolt Video Image



Beam Bolt Scan

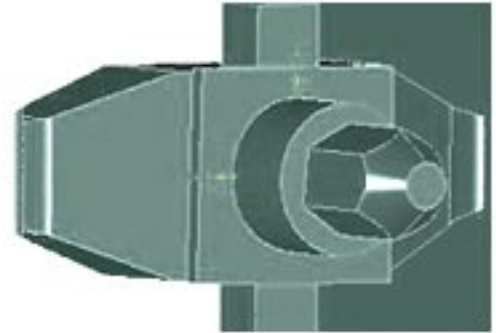

Beam Bolt Rendered as CAD File

### NM200UW Scanner Operation

- The NM200UW operates by laser triangulation. The projected laser line sweeps the target surface and the high resolution camera, centered on the target, captures and records any deformation of the line as a point cloud, enabling ultimate 3-D computation.
- The NM200UW is able to scan a target as close as 6 in. (150mm) and out to a distance of 3 ft. (0.9M) for a scan coverage area of 1.6 ft. x 2.2 ft. (500 mm x 680 mm) underwater.
- The NM200UW is designed to scan and capture much larger target areas by combining several point clouds together to form larger composites.
- Operators may select from several levels of scan quality via the user interface. The shortest, most coarse scan takes 15 seconds, while the longest and most detailed takes approximately three minutes.
- Laser light color is maximized for water penetration. The specific wavelength of the laser allows for highest possible efficiency underwater transmission.

- The scanner camera only accepts the specific color produced by its own laser and LED lights, greatly reducing any contamination from stray light in the scanning environment; thus making the NM200UW relatively immune from any other underwater work lights during operation.
- The system measures underwater targets to an accuracy of  $\pm 0.0004$  (0.01mm)\*.
- In the visual observation mode, the LED ring array on the head illuminates the area and the camera transmits a monochrome image to the control console screen to assist the operator for optimum positioning and on-site analysis.
- The control console powers and communicates with the scanner through the cable via low-voltage DC power and signals, and the camera sends scan results up via Gigabit Ethernet.
- The scanner head can be deployed by a variety of methods: pole mounting, an articulated arm, an ROV, or other robots.
- All data is permanently stored for later analysis and study.

(\*See page 5)

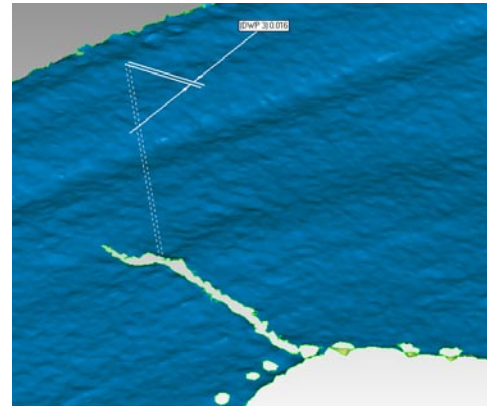
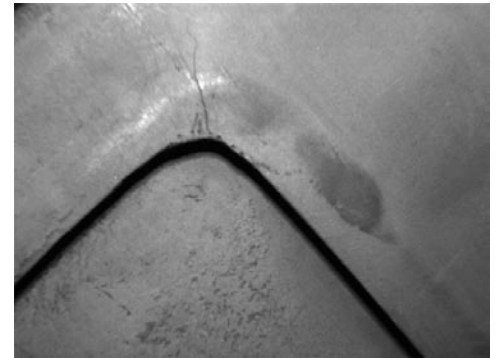

The video frame above shows a corner crack in a BWR steam dryer door. While it has been possible to determine the length of the crack by traditional "ruler-on-a-stick" means, the width and surface condition could not be accurately determined. A NM200UW scan of the area rendered to a CAD model records precise crack width and surface condition.

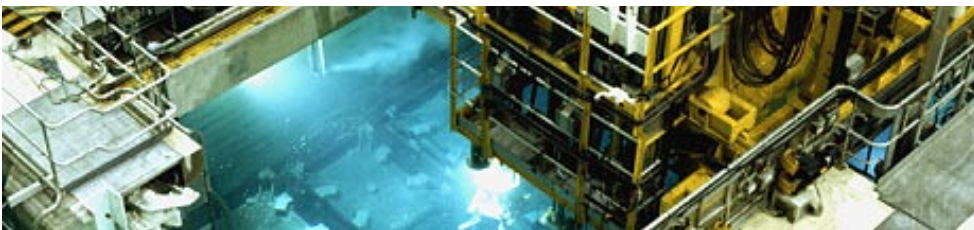

# NEWTON

**Observe, Identify and Quantify Rust, Wear, Fissures and Corrosion of Components**

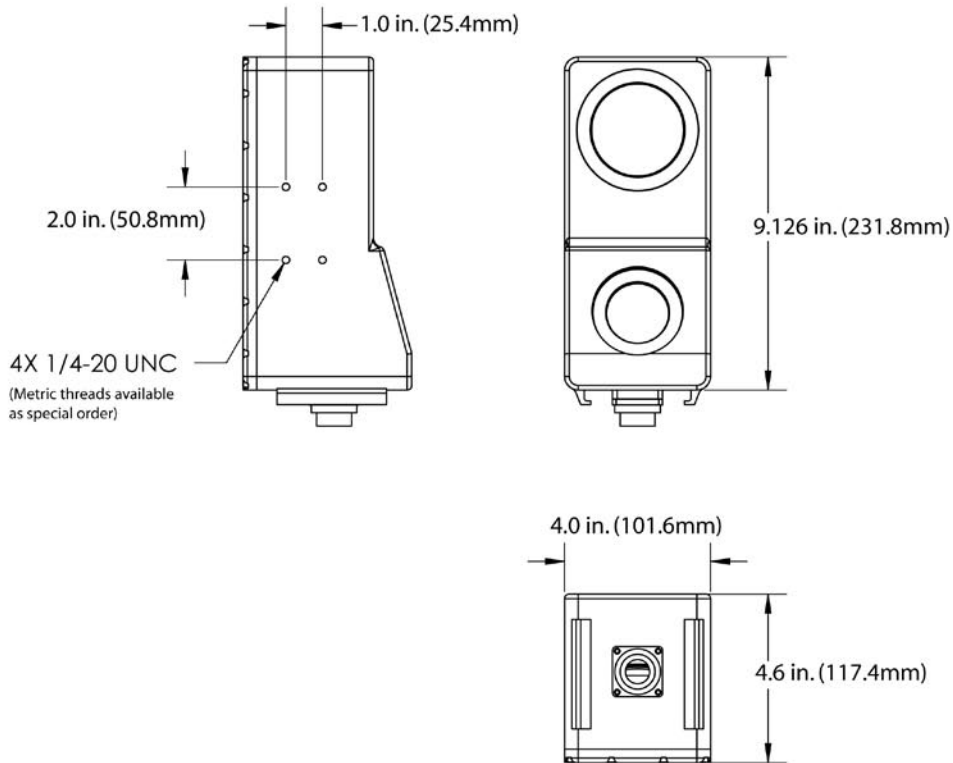
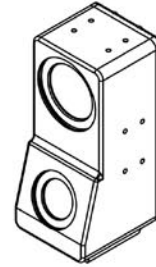

UNLESS OTHERWISE SPECIFIED DIMENSIONS ARE IN MILLIMETERS TOLERANCES: ANGULAR: $\pm 3$ ONE PLACE DECIMAL: $\pm .75$ TWO PLACE DECIMAL: $\pm .25$	NAME	DATE	441 SW 41st Street (425) 251-9600 Renton, WA 98057 www.newtonlabs.com
	DRAWN	E DWYER 9/30/2010	
	CHECKED		
	APPR.		
PROPRIETARY AND CONFIDENTIAL THE INFORMATION CONTAINED IN THIS DRAWING IS THE SOLE PROPERTY OF NEWTON RESEARCH LABS. ANY REPRODUCTION IN PART OR AS A WHOLE WITHOUT THE WRITTEN PERMISSION OF NEWTON RESEARCH LABS IS PROHIBITED.	PROJECT:	SCAN HEAD	NM-200UW
	DRAWING STATUS:		SIZE DWG. NO. A A100101
	COMMENTS:		DO NOT SCALE DRAWING SHEET 1 OF 1



## NM200UW Technical Specifications

Item	Control Unit	Laser/Camera Head
Height	9.5 in. (241 mm)	4.0 in. (102 mm)
Width	15 in. (381 mm)	4.60 in. (117 mm)
Length	22.5 in. (572 mm)	9.126 in. (233 mm)
Weight (in air)	29.2 lbs. (13.24 kg)	8 lbs. (4 kg)
Weight (in water)	---	2 lbs. (1 k) (plus cable weight)
Cable	LLDPE polyurethane jacket, gel filled - 150 ft. (45.72 m) (other lengths available)	---
Construction	Metal electronics cabinet within a molded, high-impact, airline-transportable case	Machined from solid billet of 6061T6 aluminum stock
Laser power	---	40 mW
Video camera	---	High Resolution Monochrome
LED ring array	---	2,320 lumens
Fittings & retainers	---	300 series stainless steel
Windows	---	Fused silica or optical glass
Mounting attachments	---	Four grouped 1/4-20 UNC threaded mounting holes on four sides of case (Metric threads available)
Output ports	Ethernet, USB, DVI, VGA & HDMI	---
Standard operating temperature	40° to 110° F (5° to 43° C)	110° F (43.3° C) in water - 100% duty cycle
Storage temperature	0° to 125° F (-18° to 52° C)	0° to 160° F (- 18° to 71° C)
Power input voltage/current	100 to 240 VAC 50 to 60 cycle	Powered by control unit
Data storage	Internal solid state & USB stick data	---
Output format	.ply point cloud file	---
Data file size	Approximately 100 MB per scan	---
Maximum scanner-to-target distance	---	36.0 in. (900mm)
Minimum scanner-to-target distance	---	6.0 in. (150mm)
Maximum Resolution accuracy (after processing with 3-D software)	---	+/-0.0004 in. (0.01mm)*
Scan range	---	6.0 in. (150 mm) to 36 in. (900 mm)
Watertight depth rating	---	150 ft. (45.72 m)

## System Performance

Depth of Field Distance (Distance to object)	Field of View in Water Height ----- Width		Raw Accuracy (single Point Cloud point, rms)	Approximate CAD Model Accuracy**
6 in. (150 mm)	110 mm	150 mm	+/- .002 in. (0.05 mm)	+/- .0004 in. (0.01 mm)*
12 in. (300 mm)	190 mm	250 mm	+/- .004 in. (0.10 mm)	+/- .0008 in. (0.02 mm)
18 in. (450 mm)	270 mm	360 mm	+/- .008 in. (0.20 mm)	+/- 0.04 mm (.0012 in.)
24 in. (600 mm)	350 mm	460 mm	+/- .014 in. (0.35 mm)	+/- .0025 in. (0.06 mm)
36 in. (900 mm)	500 mm	680 mm	+/- .028 in. (0.70 mm)	+/- .0060 in. (0.15 mm)

\*\*After 3rd-party 3-D software processing

\*All NM200UW accuracy is related to the field of view, distance from the object to be measured and can vary by the parameters of the object. Consult Newton for the specific accuracy that can be obtained for your proposed object.



## Information on Newton Labs and Related Products

**N**ewton Labs is a privately held developer and manufacturer of machine vision, robotics and optical automation. A spin-out from the Massachusetts Institute of Technology (MIT), the company has for more than 18 years developed and marketed high performance, computer-driven automation for industrial processes. Newton's products are designed to allow the quality, efficiency and cost effectiveness of computer technology to replace the human element in virtually every industry. Newton Labs has deployed more than 20,000 machine vision, robotic and automation systems worldwide.

In addition to the **NM200UW**, the Newton scanner product line includes the standard-duty M200UW Underwater Laser Scanner, the new M300UW Extended-Distance Underwater Laser Scanner, and soon to include the M100IP and NM100IP Internal Pipe Scanners. All scanner models produce a point cloud output so detailed that when used with industry standard 3-D software, a fully measurable CAD model can be generated.

### **For more information about these products, contact:**

Newton Labs  
lasersales@newtonlabs.com  
425-251-9600



Offices and manufacturing facilities of Newton Labs - Renton, Washington, USA

### **NM200E Core Verification System**

An industry "sister product" by Newton Labs is the revolutionary NM200E nuclear fuel assembly core mapping system for determining nozzle position in PWRs.

Newton-developed software enables the precise global mapping of fuel assembly S-hole positions, including any degree of misalignment or nozzle rotation.

The NM200E registers a field view of five by four nozzles, compared to a video micrometer's field of view that is no more than one and a half fuel nozzles wide.

The total core mapping time for the NM200E system is two hours or less.

Learn more at:  
[www.newtonlabs.com](http://www.newtonlabs.com)



The NM200E mapping head is shown within its transport frame attached to the refueling mast as it was later deployed at the Byron Generating Stations in Illinois, USA.

Rev. 012612

**NEWTON**